

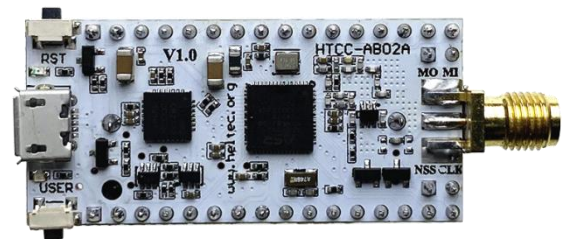

## [HTCC-AB02A](#)

# LoRa Development Board



<https://heltec.org>



## Document version

Version	Time	Description
V1.0	2020-04-30	Documents creating
V1.1	2021-04-01	Document structure update



## Copyright Notice

All contents in the files are protected by copyright law, and all copyrights are reserved by Chengdu Heltec Automation Technology Co., Ltd. (hereinafter referred to as Heltec). Without written permission, all commercial use of the files from Heltec are forbidden, such as copy, distribute, reproduce the files, etc., but non-commercial purpose, downloaded or printed by individual are welcome.

## Disclaimer

Chengdu Heltec Automation Technology Co., Ltd. reserves the right to change, modify or improve the document and product described herein. Its contents are subject to change without notice. These instructions are intended for you use.



# Content

<b>HTCC-AB02A</b> .....	<b>1</b>
<i>Document version</i> .....	<i>2</i>
<i>Copyright Notice</i> .....	<i>3</i>
<i>Disclaimer</i> .....	<i>3</i>
<i>Content</i> .....	<i>4</i>
<b>1. Description</b> .....	<b>5</b>
1.1 Overview .....	5
1.2 Product features .....	6
<b>2. Pin Definition</b> .....	<b>7</b>
2.1 Pin assignment .....	7
2.2 Pin description .....	7
<b>3. Specifications</b> .....	<b>10</b>
3.1 General specifications .....	10
3.2 Power supply .....	10
3.3 Power output.....	11
3.4 Power characteristics.....	11
3.5 LoRa RF characteristics .....	12
3.6 Operation Frequencies .....	13
<b>4. Hardware resource</b> .....	<b>14</b>
4.1 Physical dimensions.....	14
<b>5. Resource</b> .....	<b>15</b>
5.1 Relevant Resource .....	15
5.2 Contact Information .....	15



# 1. Description

## 1.1 Overview

[CubeCell](#) (TM) is a new product series made by Heltec team, mainly for LoRa/LoRaWAN node applications.

CubeCell (TM) series is based on ASR605x (ASR6501, ASR6502), those chips are already integrated with the PSoC® 4000 series MCU (ARM® Cortex® M0+ Core) and SX1262. We have done a lot of migration and development, making it perfectly [Arduino-Compatible](#)®, can run the LoRaWAN protocol stably, on-board 1/2 AA battery holder allow users use a battery easily.

HTCC-AB02A is a Dev-Board. Friendly designed for developers, easy to verify communication solutions.

HTCC-AB02A are available in two product variants:

Table 1.1 Product model list

No.	Model	Description
1	HTCC-AB02A-L	470~510MHz working LoRa frequency, used for China mainland (CN470) LPW band.
2	HTCC-AB02A-F	For EU868, IN865, US915, AU915, AS923, KR920 and other LPW networks with operating frequencies between 863~928MHz.



## 1.2 Product features

- Perfect [Arduino-Compatible!](#)
- CE and FCC certification;
- Based on ASR605x (ASR6501, ASR6502), those chips are already integrated the PSoC® 4000 series MCU (ARM® Cortex® M0+ Core) and SX1262;
- LoRaWAN 1.0.2 support;
- Ultra low power design, 3.5uA in deep sleep;
- 1/2 AA battery shell, use 1/2 AA Lithium chlorine sulfite battery (this battery can't charge, but onboard USB / battery power automatic switching allows connect USB when the battery is assembled);
- Micro USB interface with complete ESD protection, short circuit protection, RF shielding, and other protection measures;
- Integrated CP2102 USB to serial port chip, convenient for program downloading, debugging information printing;
- Good impedance matching and long communication distance.

## 2. Pin Definition

### 2.1 Pin assignment

CubeCell HTCC-AB02A Pinout Diagram

**Notes:**

- VEXT : External power supply (3.3V), control the switch of VEXT through GPIO(LOW-ON,HIGH-OFF)
- VDD : 3.3V
- VIN : 5V
- NSS1 can choose any IO port

↑ PULL-UP

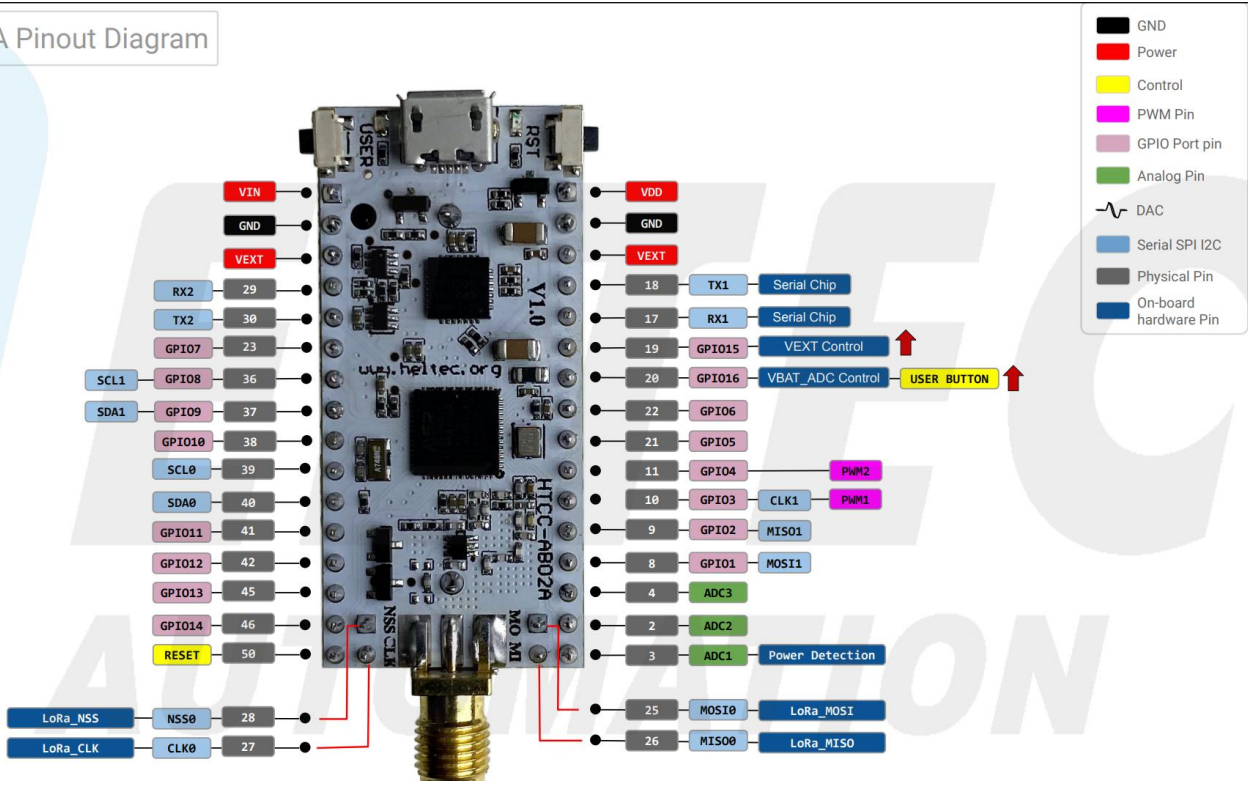

### 2.2 Pin description

#### Header P1

Table 2-2-1 Pin description

No.	Name	Type	Function
1	VIN	P	5V Input/Output.
2	GND	P	Ground.
3	VEXT	P	Output 3.3V, power supply for external device.
4	RX2	I/O	UART2_RX.
5	TX2	I/O	UART2_TX.
6	GPIO7	I/O	GPIO7.
7	GPIO8	I/O	GPIO8, SCL1.
8	GPIO9	I/O	GPIO9, SDA1.

<https://heltec.org>



9	GPIO10	I/O	GPIO10.
10	SCL0	I/O	SCL0.
11	SDA0	I/O	SDA0.
12	GPIO11	I/O	GPIO11.
13	GPIO12	I/O	GPIO12.
14	GPIO13	I/O	GPIO13.
15	GPIO14	I/O	GPIO14.
16	RESET	I	RESET.

### Header P2

Table 2-2-2 Pin description

No.	Name	Type	Function
1	VDD	P	3.3V Input/Output.
2	GND	P	Ground.
3	VEXT	P	Output 3.3V, power supply for external device.
4	TX1	I/O	UART1_TX. Connect to USB bridge chip.
5	RX1	I/O	UART1_RX. Connect to USB bridge chip.
6	GPIO15	I/O	GPIO15, VEXT Control.
7	GPIO16	I/O	GPIO16, VBAT_ADC Control, USER Button.
8	GPIO6	I/O	GPIO6.
9	GPIO5	I/O	GPIO5.
10	GPIO4	I/O	GPIO4, PWM2.
11	GPIO3	I/O	GPIO3, PWM1, SPI1_CLK.
12	GPIO2	I/O	GPIO2, SPI1_MISO.
13	GPIO1	I/O	GPIO3, SPI1_MOSI.
14	ADC3	I	ADC3.
15	ADC2	I	ADC2.
16	ADC1	I	ADC1 <sup>1</sup> .

### Header P3

Table 2-2-3 Pin description

No.	Name	Type	Function
-----	------	------	----------

<sup>1</sup> ADC1 is used to read the lithium battery voltage, the voltage of the lithium battery is:  $V_{BAT} = 2 * V(ADC1)$ .



<b>17</b>	NSS0	I/O	SPIO_NSS, LoRa_NSS.
<b>18</b>	CLK0	I/O	SPIO_CLK, LoRa_CLK.

#### Header P4

Table 2-2-4 Pin description

<b>No.</b>	<b>Name</b>	<b>Type</b>	<b>Function</b>
<b>17</b>	MOSI0	I/O	SPIO_MOSI, LoRa_MOSI.
<b>18</b>	MISO0	I/O	SPIO_MISO, LoRa_MISO.



## 3. Specifications

### 3.1 General specifications

Table 3-1: General specifications

Parameters	Description
Master Chip	ASR6502 (48 MHz ARM® Cortex® M0+ MCU)
LoRa Chipset	SX1262
USB to Serial Chip	CP2102
Frequency	470~510 MHz, 863~923 MHz
Max TX Power	22 ± 1 dBm
Receiving sensitivity	-135 dBm
Low Power	Deep Sleep 3.5µA
Hardware Resource	UART x 2; SPI x 2; I2C x 2; SWD x 1; 12-bits ADC input interface x 3; 8 – channel DMA engine; GPIO x 16
Memory	128KB internal FLASH; 16KB internal SRAM
Interface	Micro USB x 1; LoRa Antenna interface(SMA) x 1; 16 x 2.54 pin x 2+2 x 2.54 pin x 2
Battery	1/2AA Lithium
Operating temperature	-20 ~ 70 °C
Dimensions	56.6 x 24 x 21.5 mm

### 3.2 Power supply

Except when USB or 5V Pin is connected separately, lithium battery can be connected



to charge it. In other cases, only a single power supply can be connected.

Table 3-2: Power supply

Power supply mode	Minimum	Typical	Maximum	Company
USB powered( $\geq 500\text{mA}$ )	4.7	5	6	V
Lithium battery( $\geq 250\text{mA}$ )	3.3	3.7	4.2	V
5V pin( $\geq 500\text{mA}$ )	4.7	5	6	V
3V3 pin( $\geq 150\text{mA}$ )	2.7	3.3	3.5	V

### 3.3 Power output

Table 3-3: Power output

Output Pin	Minimum	Typical	Maximum	Company
3.3V Pin			500	mA
5V Pin (USB Powered only)		Equal to the input current		
Vext Pin			350	mA

### 3.4 Power characteristics

Table 3-4: Power characteristics

Mode	Condition	Min.	Typical	Max.	Company
Power Consumption(mA)	LoRa Rx Mode		10		mA
	LoRa 10dB output		70		mA
	LoRa 14dB output		90		mA



	LoRa 17dB output		100		mA
	LoRa 20dB output		105		mA
	Sleep Mode (USB powered)		9.6		mA
	Sleep Mode (VBAT/battery powered)		11		μA
	Sleep Mode (3.3V header powered)		3.5		μA

### 3.5 LoRa RF characteristics

#### 3.5.1 Transmit power

Table3-5 Transmit power

Operating frequency band	Maximum power value/[dBm]
470~510	22 ± 1
867~870	22 ± 1
902~928	22 ± 1

#### 3.5.2 Receiving sensitivity

The following table gives typically sensitivity level of the HTCC-AB02A-(L/H).

Table3-6: Receiving sensitivity

Signal Bandwidth/[KHz]	Spreading Factor	Sensitivity/[dBm]
125	SF12	-135

<https://heltec.org>



125	SF10	-130
125	SF7	-124

### 3.6 Operation Frequencies

HTCC-AB02A(F) supports LoRaWAN frequency channels and models corresponding table.

Table3-7: Operation Frequencies

Region	Frequency (MHz)	Model
EU433	433.175~434.665	HTCC-AB02A-L
CN470	470~510	HTCC-AB02A-L
IN868	865~867	HTCC-AB02SA-F
EU868	863~870	HTCC-AB02A-F
US915	902~928	HTCC-AB02A-F
AU915	915~928	HTCC-AB02A-F
KR920	920~923	HTCC-AB02A-F
AS923	920~925	HTCC-AB02A-F



## 4. Hardware resource

### 4.1 Physical dimensions

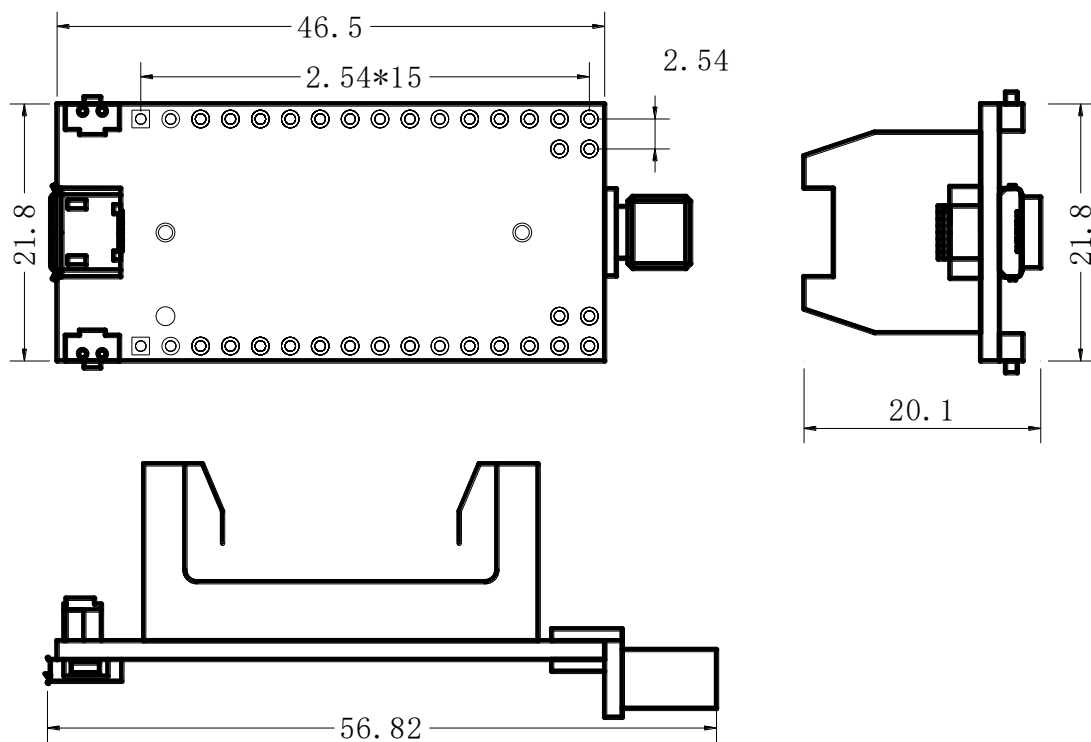



## 5. Resource

### 5.1 Relevant Resource

- [Heltec CubeCell Development framework](#)
- [Schematic diagram](#)
- [Pin map](#)
- [Downloadable resource](#)

### 5.2 Contact Information

Heltec Automation Technology Co., Ltd

Chengdu, Sichuan, China

Email: [support@heltec.cn](mailto:support@heltec.cn)

Phone: +86-028-62374838

<https://heltec.org>