



HT-N5262M

Mesh Node 5262M

Bluetooth & LoRa Module

Document Version

Version	Time	Description	Remark
Rev. 1.0.0	2024-12-16	Preliminary version	Richard

Copyright Notice

All contents in the files are protected by copyright law, and all copyrights are reserved by Chengdu Heltec Automation Technology Co., Ltd. (hereinafter referred to as Heltec). Without written permission, all commercial use of the files from Heltec are forbidden, such as copy, distribute, reproduce the files, etc., but non-commercial purpose, downloaded or printed by individual are welcome.

Disclaimer

Chengdu Heltec Automation Technology Co., Ltd. reserves the right to change, modify or improve the document and product described herein. Its contents are subject to change without notice. These instructions are intended for you use.

Content

HT-N5262M	1
<i>Document Version</i>	2
<i>Copyright Notice</i>	2
<i>Disclaimer</i>	2
<i>Content</i>	3
1 <i>Description</i>	4
1.1 <i>Overview</i>	4
1.2 <i>Variants</i>	5
1.2 <i>Product Features</i>	6
2 <i>Pin Definition</i>	7
2.1 <i>Pin Map</i>	7
2.2 <i>Pin Definition</i>	8
2.3 <i>PWM</i>	10
3 <i>Specifications</i>	11
3.1 <i>General Specification</i>	11
3.2 <i>Power supply</i>	12
3.3 <i>Power Consumption</i>	12
3.4 <i>LoRa RF Characteristics</i>	13
4 <i>Physical Dimensions</i>	15
4.1 <i>Hardware Dimensions</i>	15
4.2 <i>Footprint</i>	15
5 <i>Resource</i>	16
5.1 <i>Develop framework and lib</i>	16
5.2 <i>Recommendation LoRaWAN server</i>	16
5.3 <i>Documents</i>	16
5.4 <i>Schematic Diagram</i>	16
5.5 <i>Reference design</i>	16
5.6 <i>Related Resource station</i>	16
6 <i>Heltec Contact Information</i>	17



1 Description

1.1 Overview

Mesh Node 5262M is a module based on the nRF52840 and SX1262, supporting both Bluetooth and LoRa communication modes. It offers a rich set of pins and interfaces, featuring a 1.27mm pitch stamp hole design, making it compact and easy to integrate into your PCB.

Mesh Node 5262M can be programmed via the Arduino IDE, PlatformIO, or MicroPython. You can directly use it for LoRa/LoRaWAN development with [Heltec nRF52 framework and libraries](#), as well as to run some open source projects like Meshtastic.

Mesh Node 5262M has powerful long-distance communication capabilities, scalability, and low power design, which make it excellent in a wide range of application scenarios such as smart cities, agricultural monitoring, logistics tracking, etc.



1.2 Variants

Mesh Node 5262M are available in 3 product variants:

No.	Model	Description
1	HT-N5262M-ULF	433MHz working LoRa frequency
2	HT-N5262M-LF	470~510MHz working LoRa frequency, used for China mainland (CN470) LPW band.
3	HT-N5262M-HF	For EU868, IN865, US915, AU915, AS923, KR920 and other LPW networks with operating frequencies between 863~928MHz.

1.2 Product Features

- nRF52840 (Bluetooth)+SX1262(LoRa).
- 1.27mm pitch stamp hole design, making it compact and easy to integrate.
- Offer a rich set of pins and interfaces.
- Long transmission range, up to 3~10km in open environments^①.
- The IPEX1.0 antenna connector provides a more flexible and efficient integration solution.
- Low power consumption, 9 uA in deep sleep.
- Operation condition: -40~85°C, 90%RH(No condensing).
- Compatible with Arduino-IDE/PlatformIO/MicroPython, and we provide Arduino [development frameworks and libraries](#).

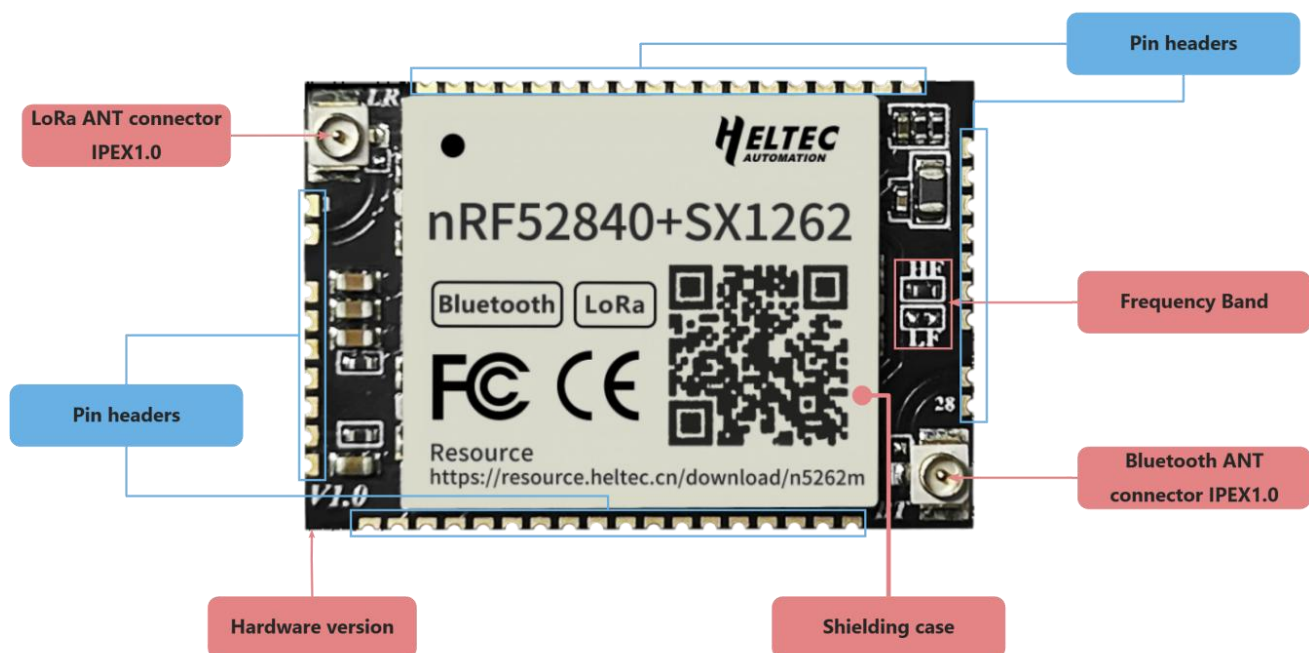

^① Depends on the environment and noise interference.

2.2 Pin Definition

Pin	Name	Type	Description
1	GND	Ground	Ground
2	ANT_LoRa	I/O	LoRa Antenna
3	P1.08	I/O	GPIO40
4	P0.11	I/O	GPIO11
5	P0.18	I/O	GPIO18, RESET
6	P0.13	I/O	GPIO13
7	P0.14	I/O	GPIO14
8	VUSB	Power	VUSB
9	GND	Ground	Ground
10	GND	Ground	Ground
11	D_N	I/O	USB_N
12	D_P	I/O	USB_P
13	P0.15	I/O	GPIO15
14	P0.16	I/O	GPIO16
15	P0.21	I/O	GPIO21
16	SWDIO	I/O	SWDIO
17	SWDCLK	I/O	SWDCLK
18	P1.00	I/O	GPIO32
19	P1.01	I/O	GPIO33
20	P1.02	I/O	GPIO34
21	P1.03	I/O	GPIO35



22	P1.04	I/O	GPIO36
23	P1.05	I/O	GPIO37
24	P1.06	I/O	GPIO38
25	P1.07	I/O	GPIO39
26	P0.09	I/O	GPIO41,NFC1,UART_RX
27	P0.10	I/O	GPIO42,NFC2,UART_TX
28	GND	Ground	Ground
29	ANT_BT	I/O	Bluetooth Antenna
30	P1.12	I/O	GPIO44
31	P1.14	I/O	GPIO46
32	P0.03	I/O	GPIO3,ADC_1
33	P1.13	I/O	GPIO45
34	P1.15	I/O	GPIO37
35	VDD	Power	3.3V Power
36	GND	Ground	Ground
37	GND	Ground	Ground
38	VDD	Power	VDD
39	P1.11	I/O	GPIO43
40	P1.10	I/O	GPIO42
41	P0.02	I/O	GPIO2,ADC_0
42	P0.29	I/O	GPIO29,ADC_5
43	P0.31	I/O	GPIO31,ADC_7
44	P0.27	I/O	GPIO27



45	P0.28	I/O	GPIO28,ADC_4
46	P0.30	I/O	GPIO30,ADC_6
47	P0.05	I/O	GPIO5,ADC_3
48	P0.07	I/O	GPIO7
49	P0.04	I/O	GPIO4,ADC_2
50	P0.26	I/O	GPIO26
51	P0.06	I/O	GPIO6
52	P0.12	I/O	GPIO12
53	P0.08	I/O	GPIO8
54	P1.09	I/O	GPIO41

2.3 PWM

HT-N5262M supports outputting PWM signals through the following pins (these pins can also be used for other functions like I2C, SPI, etc., but need to be properly configured when used for PWM output):

GPIO 0 - GPIO 31: Most of these pins can be used as PWM outputs, but the specific pins that support PWM depend on the timer and channel configuration. Most of the pins can be configured as regular GPIOs and support timer output.

For certain PWM frequency and duty cycle requirements, the software can typically control which timer channel is mapped to which GPIO pin.



3 Specifications

This section describes some commonly used important parameters. If you cannot find the information you are looking for, please refer to the [Heltec resource website](#) to check the [MCU nRF52840 manual](#) and the [LoRa chip SX1262 manual](#).

3.1 General Specification

Table3.1: General specification

Parameters	Description
MCU	nRF52840
LoRa Chip	SX1262
Memory	1M ROM; 256kB SRAM
Bluetooth	Bluetooth 5, Bluetooth mesh, BLE.
Operating temperature	-40~85°C
Operating Humidity	90%(No condensing)
Power Supply	3.3V Table3.2
Power Consumption	Table3.3
Hardware Resource	3*SPI, 2*I2C, 2*UART, 4*PWM, QPSI, I2S, PDM, QDEC, Etc.
Interface	2*ANT (IPEX1.0)), 54*1.27 stamp hole pin headers
Dimensions	30*20*3.2 m ³



3.2 Power supply

Exceeding **Absolute Maximum Ratings** may cause permanent damage to the component or severely degrade its performance.

Table 3.2: Voltage

Parameter	Min	Type	Max	Absolute Maximum Ratings	Unit
Voltage	1.8	3.3	3.6	3.9	V

3.3 Power Consumption

Table 3.3: Working current

Mode	Condition	Consumption(With backplane@3.3V)		
		470MHz	868MHz	915MHz
LoRa_TX	5dBm		90mA	97mA
	10dBm		99mA	112mA
	15dBm		113mA	128mA
	20dBm		128mA	123mA
RX		33mA		
BT	UART	137mA		
	Scan	132mA		
Sleep		9uA		



3.4 LoRa RF Characteristics

3.4.1 Transmit Power

Table3.4.1: Transmit power

Operating frequency band	Maximum power value/[dBm]
470~510	21 ± 1
863~870	21 ± 1
902~928	21 ± 1

3.4.2 Receiving Sensitivity

The following table gives typically sensitivity level.

Table3.4.2: Receiving sensitivity

Signal Bandwidth/[KHz]	Spreading Factor	Sensitivity/[dBm]
125	SF12	-135
125	SF10	-130
125	SF7	-124

3.4.3 Operation Frequencies

Mesh Node supports LoRaWAN frequency channels and models corresponding table.

Table3.5.3: Operation Frequencies

Region	Frequency (MHz)	Model
EU433	433.175~434.665	HT-N5262M-ULF
CN470	470~510	HT-N5262M-LF
IN868	865~867	HT-N5262M-HF
EU868	863~870	HT-N5262M-HF
US915	902~928	HT-N5262M-HF



AU915	915~928	HT-N5262M-HF
KR920	920~923	HT-N5262M-HF
AS923	920~925	HT-N5262M-HF



4 Physical Dimensions

4.1 Hardware Dimensions

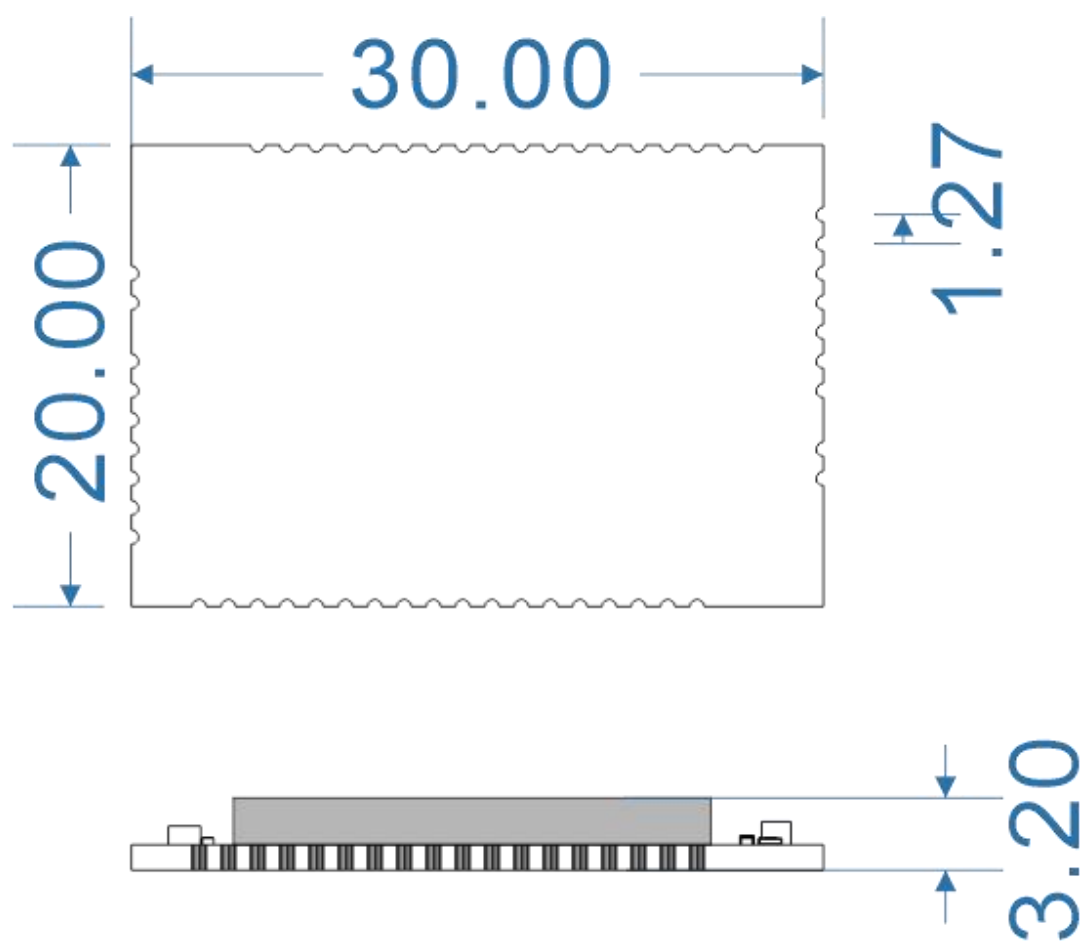

[-1:1 original image download link](#)

4.2 Footprint

[Heltec Module Footprint](#)



5 Resource

5.1 Develop framework and lib

- [Heltec nRF52 framework and Lib](#)

5.2 Recommendation LoRaWAN server

- [SnapEmu IoT Platform](#)

5.3 Documents

- [Manual Document](#)

5.4 Schematic Diagram

- [Schematic Diagram](#)

5.5 Reference design

- [Reference design](#)

5.6 Related Resource station

- [Resource station](#)



6 Heltec Contact Information

Heltec Automation Technology Co., Ltd

Chengdu, Sichuan, China

Email: support@heltec.cn

Phone: +86-028-62374838

<https://heltec.org>