



MeshTower

Solar-Powered Outdoor Mesh Hub



Document Version

Version	Time	Description	Remark
Rev. 1.0	2025-6-16	Preliminary version	Richard

Copyright Notice

All contents in the files are protected by copyright law, and all copyrights are reserved by Chengdu Heltec Automation Technology Co., Ltd. (hereinafter referred to as Heltec). Without written permission, all commercial use of the files from Heltec are forbidden, such as copy, distribute, reproduce the files, etc., but non-commercial purpose, downloaded or printed by individual are welcome.

Disclaimer

Chengdu Heltec Automation Technology Co., Ltd. reserves the right to change, modify or improve the document and product described herein. Its contents are subject to change without notice. These instructions are intended for you use.

Content

<i>MeshTower</i>	1
1 Description	4
1.1 Overview	4
1.2 Features	5
1.3 Typical Applications	5
3 Specifications	6
4 Electrical Characteristics	7
4.1 Voltage Input	7
4.2 Charging Current	7
5 RF Characteristics	8
5.1 RF module power consumption	8
5.2 LoRa Transmit Power	8
5.3 LoRa Receiving Sensitivity	9
5.4 LoRaWAN Operation Frequencies	9
5 Physical Dimensions	10
5.1 Enclosure	10
5.2 LoRa Antenna	
5.3 Solar Panel	11
6 Resource	12
6.1 HT-N5262M Schematic	12
6.3 MeshTower Resource Station	12
6.4 Heltec nRF52840 Framework	12
7 Heltec Contact Information	12



1 Description

1.1 Overview

MeshTower is a solar-powered outdoor communication system built on MeshSolar technology, featuring an integrated 18V solar panel and 3 × 3000mAh lithium battery for sustained operation. With Bluetooth + LoRa dual-mode connectivity and SMA antenna support, it ensures robust signal coverage. Housed in an IP66-rated waterproof metal enclosure and designed for -20 ° C to 60 ° C environments, it thrives in harsh conditions. Offering pole/wall-mount flexibility, it 's ideal for remote monitoring and off-grid communication—delivering solar endurance and industrial resilience.

MeshTower is categorized into the following variants based on supported LoRa frequency bands:

HT-n5262G: Hardware Version Information

Module	Frequency	Battery
HT-n5262G-LF	470~510MHz	Li-ion
HT-n5262G-HF	863~928MHz	Li-ion



1.2 Features

- ❏ Developed based on the MeshSolar board, integrated with 3×2800mAh high-capacity lithium batteries.
- ❏ Professional BMS Performance, features comprehensive protection including overcharge/over-discharge/short-circuit/over-temperature safeguards etc.
- ❏ 18V solar input, adjustable panel angle.
- ❏ Supports DC 18-24V and USB-C PD3.0 input.
- ❏ Dual Support for LoRa & Bluetooth.
- ❏ External SMA antenna compatible.
- ❏ Excellent Low-Power Efficiency.
- ❏ Wide-Temperature Battery (-20°C to 60°C).
- ❏ IP65-rated metal enclosure, waterproof & flame-retardant.
- ❏ Easy installation, supports pole mounting and wall mounting.

1.3 Typical Applications

- 📍 Environmental Monitoring Systems
- 📍 Smart Agriculture & Livestock Farming
- 📍 Asset Management and Tracking
- 📍 Outdoor Emergency Solutions
- 📍 Solar Street Lighting Systems
- 📍 Industrial Infrastructure Monitoring
- 📍 Open-source projects like such as Meshtastic

3 Specifications

Table3.1: General specification

Parameters	Description
BMS chip	BQ4050, CN3795
RF chip	Nordic nRF52840(BLE), SX1262(LoRa)
Chip Memory	1M ROM; 256kB PSRAM
Wireless	BLE, LoRa
GNSS Module(Optional)	Quectel L76K
Battery Capacity	3*2800mAh
Battery Type	Li-ion Battery
Voltage Input	DC 18-24V(XT30), PD3.0 20V(USB-C)
Panel Voltage	18V/10W
LoRa TX Power	21 ± 1dBm
Interface	SMA (RP-SMA) female jack antenna connector, USB-C, XT30 Panel Interface
Operating Temperature Range	-20~60°C
Protection Rating	IP66
Dimensions	Enclosure: 125 (+40) * 125 * 52 mm Solar Panel: 340*220 mm
Weight	1.52kg
Enclosure	Aluminum



4 Electrical Characteristics

4.1 Power Input

The Solar/DC input supports both solar panel and DC power sources, with a requirement that the **V_{oc}**(open-circuit voltage) must exceed 18V not exceed 24V. The USB-C port only enables charging functionality when it detects a PD3.0 protocol with a 20V input voltage; a 5V input is solely for powering the MCU.

Table4.1: Voltage Input

Input Method	Parameter
Solar Panel	18V/10W
DC	18V-24V, ≤1.5A
USB-C(Charging)	PD3.0, 20V
USB-C(MCU)	5V

4.2 Charging Current

Table4.2: Changing Current

Method	Current	Description
Solar Panel	0.55A	Depends on the solar panel's power and voltage. The minimum is >0, while the maximum = P_{solar} / V_{solar}
DC@18V	1.5A	Constant-current charging at 1.5A, tapering down when battery voltage reaches 4.2V
USB-C(PD3.0)	1.5A	Constant-current charging at 1.5A, tapering down when battery voltage reaches 4V



5 RF Characteristics

5.1 RF module power consumption

The test data comes from the standalone test results of the HT-N5262M, using the sample code from the official [Heltec nRF5240 library](#).

Table5.1: Transmit power

Mode	Condition	470MHz	868MHz	915MHz
LoRa_TX	5dBm	63mA	89mA	97mA
	10dBm	85mA	119mA	130mA
	15dBm	110mA	145mA	156mA
	20dBm	128mA	164mA	166mA
BT	UART	12mA		
	Scan	4mA		
Sleep		8uA		

5.2 LoRa Transmit Power

Table5.2: Transmit power

Operating frequency band(MHz)	Maximum power value/[dBm]
470~510	21 ± 1
863~870	21 ± 1
902~928	21 ± 1

5.3 LoRa Receiving Sensitivity

The following table gives typically sensitivity level.

Table5.3: Receiving sensitivity

Signal Bandwidth/[KHz]	Spreading Factor	Sensitivity/[dBm]
125	SF12	-135
125	SF10	-130
125	SF7	-124

5.4 LoRaWAN Operation Frequencies

HT-n5262M supports LoRaWAN frequency channels and models corresponding table.

Table5.4: Operation Frequencies

Region	Frequency (MHz)	Model
433	433	HT-N5262G-ULF
C470	470-510	HT-N5262G-LF
IN868	865~867	HT-N5262G-HF
EU868	863~870	HT-N5262G-HF
US915	902~928	HT-N5262G-HF
AU915	915~928	HT-N5262G-HF
KR920	920~923	HT-N5262G-HF
AS923	920~925	HT-N5262G-HF



5 Physical Dimensions

5.1 Enclosure

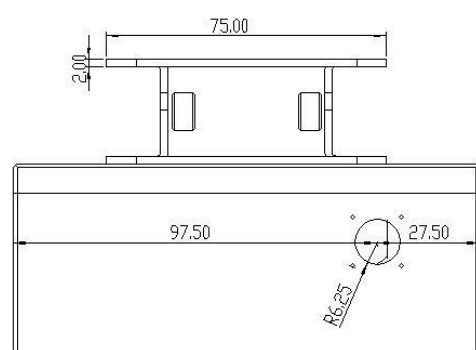
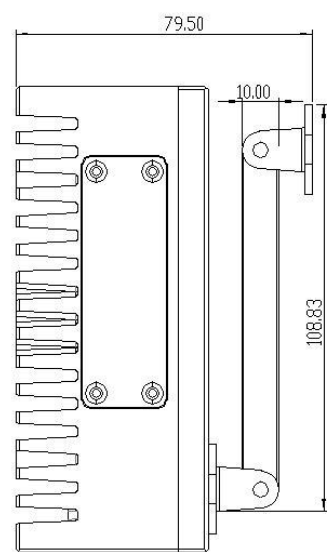
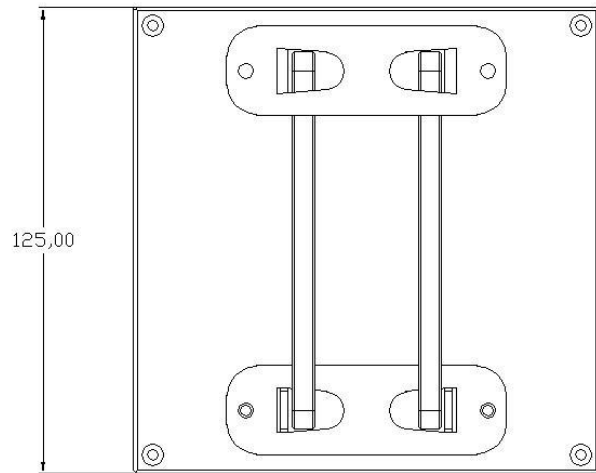
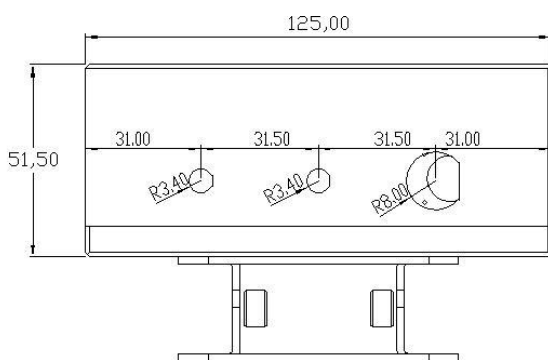



5.2 LoRa Antenna

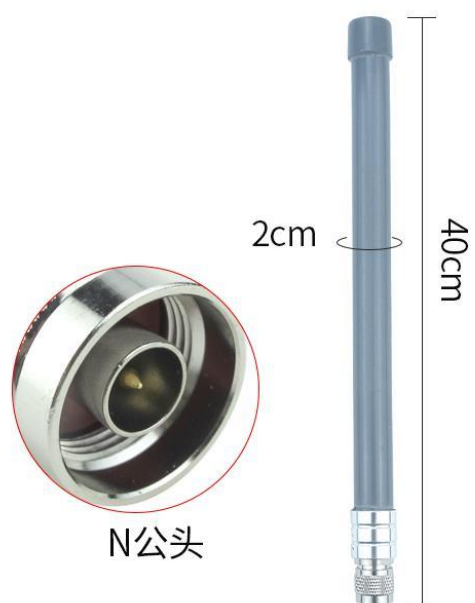

5.3 Solar Panel

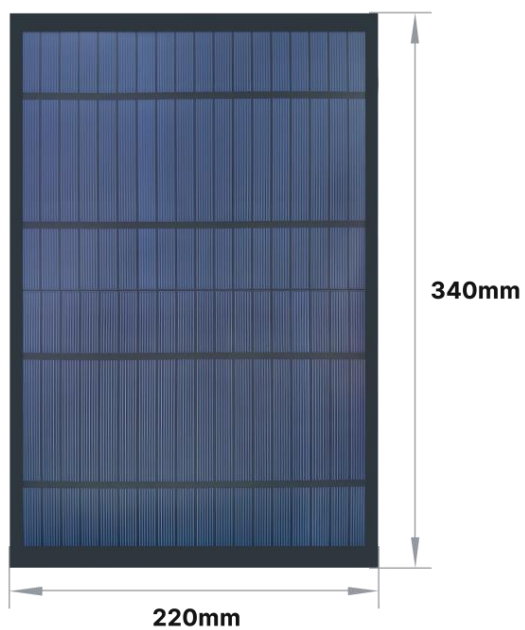



6 Resource

- 6.1 [HT-N5262M Schematic](#)
- 6.2 [MeshTower Resource Station](#)
- 6.3 [Heltec nRF52840 Framework](#)
- 6.4 [BMS Management and Fault Diagnosis](#)

7 Heltec Contact Information

Heltec Automation Technology Co., Ltd

Chengdu, Sichuan, China

Email: support@heltec.cn

Phone: +86-028-62374838

<https://heltec.org>